

# INTRODUCING CORNERSTONE VALVE GENUINE IN-LINE REPAIRABILITY

Save time and money with Novaspect. Experience fast delivery of custom products and parts from a North American supply chain. Receive a 5 year zero-leakage guarantee in steam applications.

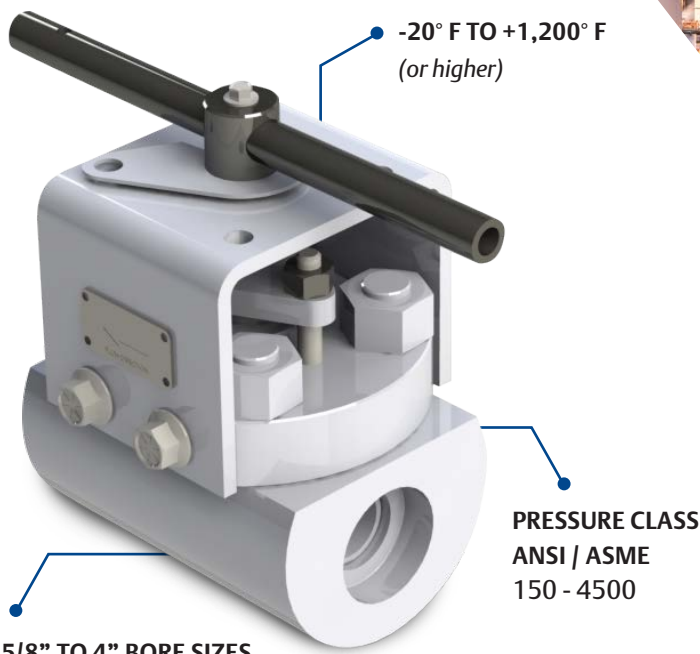

**5/8" TO 4" BORE SIZES**  
*(Larger sizes available upon request)*

**60 MONTH (5 YEAR)  
ZERO-LEAKAGE GUARANTEE**

## TE-4 AND TE-1 STANDARD FEATURES

- One-piece rigid body design: for optimal strength, versatility, and minimal leak paths.
- Metal-to-metal body/bonnet seal: zero leakage, "bubble tight".
- "Fits only one way" lever handle.



## KEY FEATURES

- Truly In-line repairable: No need to "cut the valve out" of service when maintenance is required (unlike end-entry, uni-body, and 3-pc designs).
- Metal-seated, top-entry, floating design.
- Leak tested with high pressure nitrogen gas, achieving zero bubbles.
- 360 degree-lapped to remove coating transition peaks (eliminates high friction/torque when cycled).
- Modular trim kit allows for simple and fast repair with a factory trim set.
- Available with weld pups factory installed (eliminates field welding dissimilar metals in transition areas).

**Contact Novaspect For a Quote Today!**

1 877 509 8020 | TOLL-FREE 24 / 7 / 365 | [www.Novaspect.com](http://www.Novaspect.com)

